



VELFAC LTD
 The Old Livery
 Hildersham
 Cambridge
 CB21 6DR

T: 01223 897100
 F: 01223 897101
 customerservices@VELFAC.co.uk
 www.VELFAC.co.uk

VELFAC Ireland Ltd.
 Unit H
 Citywest Shopping Centre
 Citywest
 Dublin 24
 T: 01 421 5112
 F: 01 4039548
 customerservices@VELFAC.ie
 www.VELFAC.ie

07.39-12.1.1 © 2005, 2011 VELFAC LTD. VELFAC and VELFAC logo are registered trademarks used under license by VELFAC Group.



WINDOWS FOR LIFE

WINDOWS FOR LIFE



User guide



Welcome to VELFAC Windows

Our commitment to quality ensures that your VELFAC windows will retain their looks and functionality for years with the minimum of care.

In this guide you will find an introduction to some of the benefits of VELFAC windows, questions and answers regarding your 12 Year Warranty, useful tips on the security of your property, and information about our environmental policies.

- On page 6 you will find advice about how to maintain your VELFAC windows and doors.
- On page 7 you will find advice about condensation and how to prevent it.
- On page 11 you will find illustrations and an explanation of the technical terms used in this guide to describe the functionality of your windows.
- You will also find a guide on page 11 to establish which VELFAC window system you own. You need this in order to read more about how your windows function.
- Pages 12-27 describes in detail how to operate your windows and doors. You will find information about adjusting the friction arm and where to lubricate your windows to ensure smooth operation.

We hope that by using this guide, you will be able to make the most of your VELFAC windows and enjoy them for many years to come.

Please feel free to contact us if you have any questions which are not answered in this User Guide.

Kind regards
VELFAC LTD

T: 01223 897100
W: www.VELFAC.co.uk

CONTENTS

VELFAC 200 Reversible window	16
Internal sash for VELFAC 200 windows	17
VELFAC 200 Patio door	18
VELFAC 200 Sliding door	19
VELFAC 400i Tophung projecting window	20
VELFAC 400i Fixed window	20
VELFAC 400i Reversible window	21
VELFAC 400i Sidehung window	22
VELFAC 400i Sidehung projecting window	23
VELFAC 400i Patio door	24
2-leaf VELFAC 200 and 400i windows and patio doors	25
VELFAC 100 Inward opening window and patio door	26
VELFAC 600 Entrance doors	27
Handles and remote operation	28
Safety fittings and other accessories	29
Operation failure, damage or break-ins	30
VELFAC after sales service	31

Welcome	2
In this guide you will find	2
Life, light and fresh air	3
Safety and security	4
Energy and environment	5
How to care for your VELFAC windows	6
Condensation on your windows	7
Quality standards for the window industry	8
12 year product warranty	10
Which type of windows do you have?	11
Technical terms	11
VELFAC 200 Tophung projecting window	12
VELFAC 200 Tophung window	13
VELFAC 200 Fixed window	13
VELFAC 200 Sidehung window	14
VELFAC 200 Sidehung projecting window	15

Light, life and fresh air

The slim, elegant sightlines of a VELFAC aluminium and wood window provide brighter interiors, than traditional windows, increasing the feeling of light and space within a room. This natural light helps increase your feeling of well being, even on a dark January day.

In addition to bringing natural light into our homes, we must also ensure the internal air quality is good, so:

- Air rooms thoroughly two or three times a day for at least 10 minutes, even when raining
- Maintain a consistent indoor temperature of 20-22°C
- Ensure good air circulation in all rooms - leave internal doors between rooms open

VELFAC windows use the best raw materials available, sourced from environmentally conscious suppliers. The combination of high performance glazing, internal wood frame and external aluminium sash provides a service lifetime of 40 years or more.



A life in safety and security

Burglars can enter a building through a window either by breaking the glass or frame, picking the lock, or removing the glass panes entirely. VELFAC windows resist all such forms of attack.

VELFAC windows are internally beaded so it is impossible to remove the glass from the outside; the double-glazed panes require considerable force, and resulting noise, to break; the frames are designed to withstand even the most determined criminal. Lockable handles can further enhance the security of each window, and specially designed child-locks also provide a safer environment for families.

Secured by Design is an initiative launched by the Association of Chief Police Officers Crime Prevention Initiatives, and is backed by the Home Office Crime Reduction Unit. The programme encourages the building industry to adopt crime prevention measures as part of development design. The aim is to reduce the opportunity for crime, and the fear of potential crime, resulting in a safer and more secure environment.

VELFAC windows have been put through several severe tests which replicate forced entry, and the following opening functions are Secured by Design accredited:

- VELFAC 200 Sidehung window
- VELFAC 200 Fixed window
- VELFAC 200 Tophung projecting window
- VELFAC 200 Patio door



► Stop the thief - before he brakes in

- Make it look like you're at home, even if you're out
- Ask a neighbour to empty your mailbox and use the dustbin when you're away from home
- Install movement responsive sensor lights outside
- Place valuables out of sight



► Glazing beads are located inside VELFAC windows. This means a thief cannot unclip the glazing bead and remove the glass pane.

Energy and environment

VELFAC and energy. It has been proven that windows and doors are the main sources of heat loss from a building. In order to reduce this loss, it is important that high performance windows are installed.

The pine frame of a VELFAC window possesses the natural insulating properties of wood. The double-glazing incorporates a low-energy coating and contains argon between the panes of glass - the argon provides better insulation than air. The slim frame also allows more light to enter the room, generating free heat from the sun known as solar gain. This combination means you gain lots of sunlight, free solar heating and that your windows are some of the most energy efficient around.

VELFAC and the environment. VELFAC has long recognised the need to care for and protect the environment, and this philosophy lies at the heart of all that the company does; a unique demonstration of how a major manufacturer can implement an effective environmental policy.

VELFAC applies strict principles to every stage of the design, production and installation process: wood is sourced from FSC or PEFC accredited suppliers, 50% of the aluminium used in the production of VELFAC profiles comes from recycled sources, 85% of which is produced using hydro-electricity.

In order to measure the real impact of a product upon the environment, all aspects - such as energy consumption, use of resources or waste disposal - must be analysed at all stages of a window's life.

In collaboration with the Technological Institute in Denmark, VELFAC has undertaken a 'cradle to grave' analysis of window performance, with the results published as an 'Environmental Declaration'. The document contains an analysis of all materials used in window production, and gives a measure of environmental impact across five distinct areas: Raw materials, Production processes, Window performance and use, Disposal and Transport. To download a copy, please visit www.VELFAC.co.uk



► In a VELFAC window the sash is installed directly on the frame. This results in slim sightlines and a much bigger glazing surface, which allows free solar energy and a maximum of daylight to enter the building.



► VELFAC is the first window system with an environmental declaration.

How to care for your windows to ensure warranty

The correct cleaning and maintenance of your windows and doors will keep them looking good and ensure they will resist even the harshest weather conditions for years to come. Please observe the below instructions to make sure, that the product warranty is maintained.

Washing and oiling. Once installed, a VELFAC window virtually takes care of itself - all it needs is regular cleaning, and oiling of the hinges, handle and locking mechanism (see page 28) once or twice a year - frequently used windows and doors more often. Pages 12-27 contain diagrams showing the parts which require oiling, indicated by 2 drops of oil. 

Window glazing should be cleaned with a soft cloth or soft bristle brush and luke warm water with a few drops of mild detergent - detergents must not contain solvents or abrasives. Traces left on the glass after removing stickers or glue can be cleaned with meths or other alcohol based substances. Marks from suckers can be removed with a cleaning agent for glass ceramic hobs. To dry the window, use a window scraper, or wipe with a slightly damp Chamois leather or fine cloth.

The external window sash is made from aluminium with a powder coated finish. It will need cleaning at least once a year with a soft cloth or soft bristle brush and luke warm water with a few drops of mild detergent. Black stripes from gaskets will be harder to remove, if allowed to sit for long. Materials such as paint, wet concrete etc. must be washed off immediately. A scratch will not affect the durability of the sash as the aluminium will form a natural layer of oxide. Scratches in the aluminium can be repaired with repair lacquer, but differences in colour may occur.

The window frame is manufactured from pine which has been coated with a 100% water-based acrylic lacquer or acrylic paint. The internal frame should be dusted and wiped clean regularly. The glazing bead, weather seals and gaskets should be cleaned using a damp cloth.

A break of the surface treatment on either side of the frame, must be repaired promptly. The surface treatment should be checked once a year. Should a repair be required to the wood frame, use a water-based acrylic paint or acrylic lacquer - avoid getting paint on the seals, gaskets and glazing beads.

Repair paint or lacquer (guide enclosed) can be purchased from VELFAC After Sales Service Department. To order the original colour please state the order number, see page 30.



► Your windows will need more regular maintenance if they are exposed to strong sunlight on South facing facades, if you live in a marine or industrial environment, or if you have high levels of internal humidity.



► **Resin.** Wood is a natural product containing resin. Beads of crystallised resin can be removed by gently rubbing with a cloth dampened with meths. Do not rub too hard, a better result comes from rubbing moderately with meths several times. Immediately after rubbing wipe off the resin and meths with water. Larger beads of resin may need months to crystallise before they can be scraped off and finally wiped with meths. Yellowing due to the knots fade gradually with age.

Condensation on your windows

Condensation appears naturally, when humid warm air meets cold air. Most people have experienced condensation on their bathroom mirror, the same principle applies to windows of a house.

Exterior condensation. Due to the low-energy double-glazing used in VELFAC windows, condensation may form on the outside. During colder months, the outer pane cools faster than the inner pane and moisture in the external atmosphere forms small droplets of water against the glass. This kind of condensation is completely harmless to the window and will disappear as the external temperature increases.

Internal condensation has to be dealt with to keep it to an absolute minimum, though it may not be completely avoided. It forms when warm moisture held in the internal atmosphere cools against the glass and forms small droplets of water. Because warm air can hold more moisture, condensation increases as the room temperature is lowered and improves as the temperature rises.

Heavy condensation indicates high humidity due to poor air circulation. A humid indoor climate is unhealthy for both people and windows, therefore a relative internal humidity of maximum 45% during winter is recommended. There are three important measures to combat condensation:

- Rooms should be aired thoroughly two or three times a day for at least 10 minutes, even when raining
- A consistent indoor temperature of 20-22°C should be maintained
- Good air circulation in all rooms should be ensured - leave internal doors between rooms open

Condensation between the two glazing panes. If condensation forms between the two glazing panes, the sealed double-glazed unit has been punctured and must be replaced. Please call the VELFAC After Sales Service Department.



- Did you know that...
- You must air new-build properties more regularly than old ones - this also applies to refurbishments or extensions
 - People give off approximately 2L of water every 24 hours - airing is the only way to remove it
 - Pot plants deliver most moisture
 - Condensation increases as the room temperature is lowered and improves as the temperature rises.

If condensation has recently formed, it may be due to:

- Recently installed windows which are completely air tight
- Installation of under floor heating
- New curtains
- Moisture in new houses - it may take as long as a year to dry a new house completely
- The season - condensation is more likely to occur in autumn and winter.

Quality standards for the window industry

VELFAC manufactures windows to meet the very highest expectations. The quality of our parts and materials, with the best possible standards in manufacturing, combine to provide the VELFAC windows you expect.

We have also implemented some simple guidelines for our customers, which identify quality standards, and what is allowable for predominately natural materials - wood, aluminium & glass.

Aluminium

Visible aluminium surface defects that are not visible from 3m are acceptable and therefore not claimable. Surfaces should not be assessed in direct sunlight.

Wood

Pine trees used in the production of frames for VELFAC windows are grown in North-European forests, which mean they mature slowly - as a result the wood is denser and harder-wearing than standard pine. Wood is a natural material that is often uneven. We are making very specific demands on our suppliers to get a wood quality, which we can vouch for.

We treat the wood surface following the below mention rules:

- All surfaces should be treated with 100% water based acrylic paint or acrylic lacquer
- Surfaces, edges and joins must be uniform in color and gloss and be smooth to the touch
- Because wood is a natural product, there may be structural and gloss variations, scratches and other normal wood variations (e.g. in connection with knots)
- Wood contains natural resin. During the first 3-4 years, resin leakage may occur and crystallise on the wooden frame. See treatment of resin extraction on page 6

Page 6 describes the maintenance requirements for the wood frame. Special consideration should be given to windows on South facing facades, in coastal locations, or where there is a high moisture content inside the room. The surface treatment should be checked at least once per year, and any break in the lacquer or paint should be repaired promptly.



► Polyester powder coated aluminium is extremely weather resistant and does not rust or corrode.



► As wood is a natural material, some variations in finish are unavoidable e.g. where knots occur. VELFAC wood frames are laminated to limit these occurrences.



► The Glass and Glazing Federation (GGF) publishes guidelines of modern glazing manufacture.

Please visit <http://www.ggf.org.uk/>

Glazing

All glazing is supplied by specialist manufacturers, and is produced within agreed standards outlined by the Glass and Glazing Federation (GGF). Glass impurities cannot be completely avoided, so minor occurrences are allowable within these standards. The document 'Visual quality standards for installed insulation glass units constructed from flat transparent glass', states the following:

- Both panes of sealed unit shall be viewed at right angles to the glass from the room standing at a distance of not less than 2 metres for toughened, laminated or coated glass, not less than a distance of 3 metres in natural daylight and not in direct sunlight.
- Flat transparent glass, including laminated or toughened (tempered) glass shall be deemed acceptable if the following phenomena are neither obtrusive nor bunched: totally enclosed seeds, bubbles or blisters: hairlines or blobs: fine scratches not more than 25mm long; minute embedded particles

Impurities, dirt and scratches. Larger scratches or marks within the glazed unit will be considered for replacement under the 12 Year Warranty - please contact VELFAC with details. Scratches or marks on the external face of the glazed units cannot be covered by the warranty, as they are a result of handling after the transport packing has been removed. If the damage is a result of installation, please contact your installer.

Shades. Ordinary glass used in double-glazing is generally taken to be clear - but it is actually green. The colour reduces light transmission. Therefore, two pieces of glass of the same type but with different thicknesses can be perceived as if they have different shades of colour - this cannot be addressed.

Uneven heat across the glass surface can cause cracks due to thermal stress, which is not covered by warranty.

Therefore, we advise that you do not:

- attach adhesive posters or signs to the window
- paint the window completely or partially
- attach adhesive plastic film or filters to the window
- create areas of partial shadow/shading
- blow hot air on the window (blow dryer, space heater, etc.)

12 year product warranty

The **warranty** covers manufacturing and material defects within a period of 12 years from delivery date - front doors 5 years.

The warranty does not cover failures caused by improper installation, missing or inadequate maintenance or improper operation. Incorrect installation should be addressed with the window installer.

Below you can find a selection of questions we are frequently asked. If, however, you have a technical question which is not included, please call us on 01223 897100.

Question: I have new windows, but they do not operate properly.

Answer: New windows should work perfectly and it is up to the window fitter to ensure they do before handing over the building. You should consult your window installer and ask him to look into the matter.

Question: I had new windows installed a few years ago. Now there are yellowish-brown stains on the paint.

Answer: Wood is a living product, so resin is a natural condition. This is caused by knots, but as VELFAC windows are virtually knot free, this condition is not common.

Question: My VELFAC windows and doors are 14 years old, but now they do not operate properly.

Answer: It may be that the sash has dropped or shifted due to setting over time. The sash can be adjusted. See www.VELFAC.co.uk to find our Installation Guide with instructions on how you can adjust VELFAC windows and doors. Alternatively, you can contact our After Sales Service Department for a quotation for this work.

Question: I have newly installed windows in my house, and I can see that there are scratches on the glass.

Answer: Glass imperfections cannot be completely avoided, so minor occurrences are allowable within the guidelines of modern glazing manufacture - for more information contact the Glass and Glazing Federation (GGF). Larger scratches or marks within the glazed unit will be considered for replacement under the 12 Year Warranty - please contact VELFAC with details. Scratches or marks on the external face of the glazed units cannot be covered by the warranty, as they are a result of handling after the transport packing has been removed. If the damage is a result of installation, please contact your installer.

Question: My windows are no more than a few months old, and already they need to be oiled.

Answer: It is possible windows and doors only a few months old need oiling as when VELFAC windows leave the factory, they are lubricated, but only minimally so as not to attract dust and dirt. The next time the hinges and locker mechanism need cleaning and lubricating depends on how often the windows and doors are opened and closed, wind and weather in the area, and the season.

Question: I am unable to close my window.

Answer: Have you disengaged the restrictor? Refer to page 29 for further guidance.

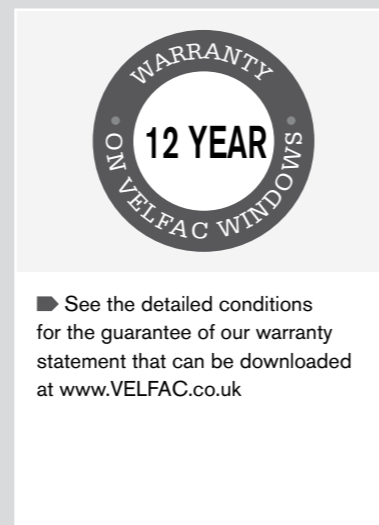

Which type of window do you have?

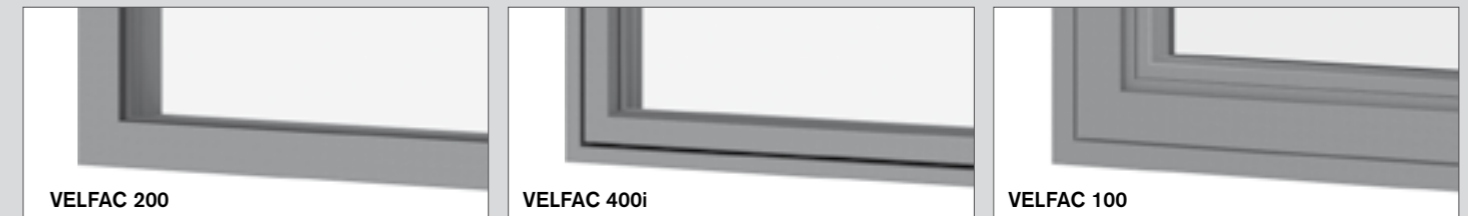

You need to establish which VELFAC window system you have to understand how they operate and what adjustments are possible. Please take a look at the diagrams and the descriptions to decide which of VELFAC 200, VELFAC 400i or VELFAC 100 windows you own.

VELFAC 200 windows have a single sightline on the external side.

VELFAC 400i windows have a double sightline on the external side.

VELFAC 100 windows are inward opening.

Technical terms

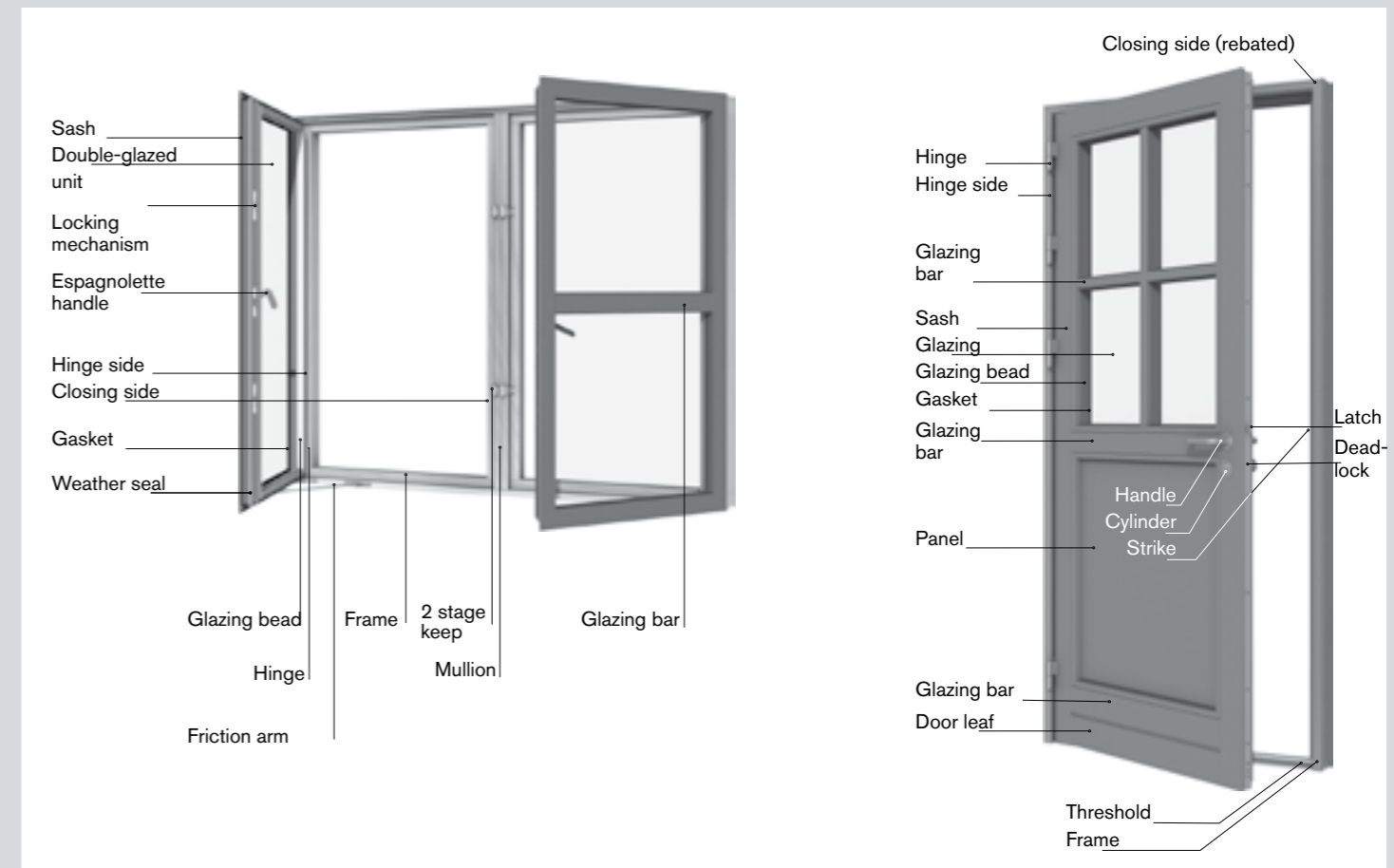

VELFAC 200 Tophung projecting window



This window is opened by turning the handle to a vertical position and pushing the sash outwards. Opening the window will provide a ventilation gap at the head.

Friction arm adjustment. Friction can be adjusted by turning the friction screws at the sides of the sash using a 4mm hexagon key. (1). Each screw is adjusted equally to keep the sash level and square.

Cleaning. Ensure that guide rails are free from dust and dirt by using a soft brush or cloth (2). The guide rails should not be oiled as this will accumulate dust and dirt, and remove friction.

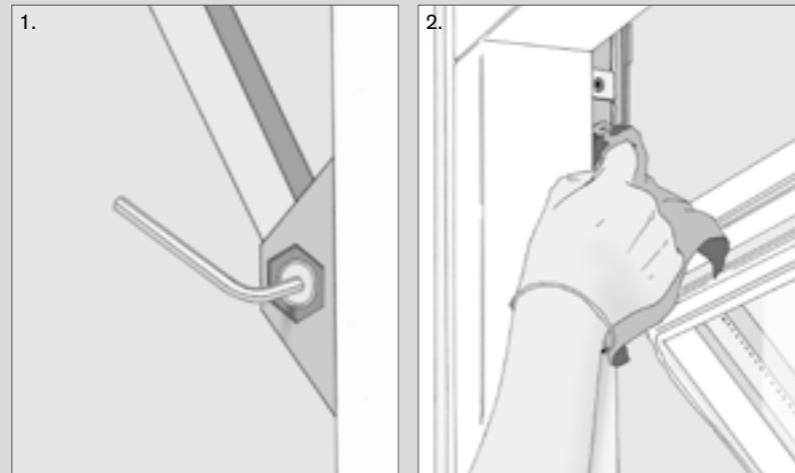

This window is equipped with:	See more
Espagnolette handle	p. 28
Ventilation position	p. 28
Friction arm	p. 29

It can also be fitted with:	See more
Espagnolette handle with child-lock	p. 28
Espagnolette handle with lock	p. 28
Espagnolette handle for cylinder lock	p. 28
Electric opener for remote operation	p. 28
Safety restrictor	p. 29
PN-fitting	p. 29
Lockable restrictor	p. 29
Click vent	p. 29
Integral blind	p. 29

VELFAC 200 Tophung window

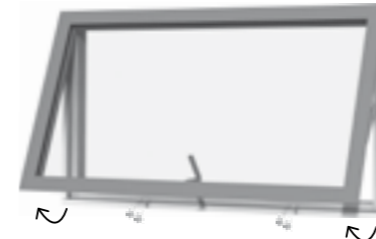

This window is opened by turning the handle to a vertical position and pushing the sash outwards.

If the window is installed as a fire escape window it will, when opened at maximum, be fixed in a vertical position by a catch in the left-hand side. (1). To close the sash, detach the catch.

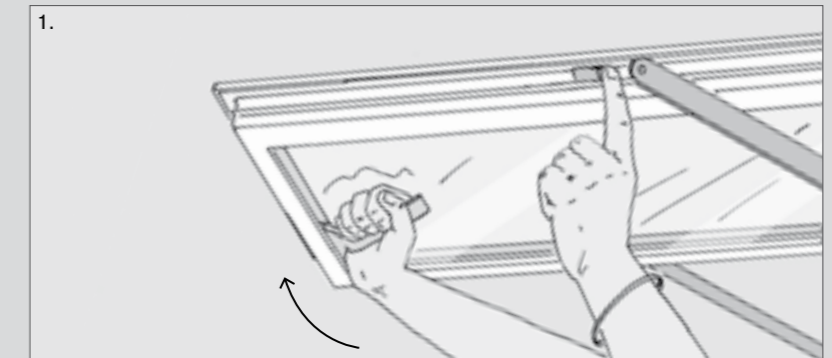

This window is equipped with:	See more
Espagnolette handle	p. 28
Ventilation position	p. 28

It can also be fitted with:	See more
Espagnolette handle with child-lock	p. 28
Espagnolette handle with lock	p. 28
Espagnolette handle for cylinder lock	p. 28
Electric opener for remote operation	p. 28
PN-fitting	p. 29
Lockable restrictor	p. 29
Click vent	p. 29
Integral blind	p. 29

VELFAC 200 Fixed window



A fixed window cannot be opened and therefore requires no maintenance or adjustments of opening fittings.

Fixed windows can be converted to opening. Please call VELFAC After Sales Service on 01223 897100 (UK) or 01 421 5112 (IRL) for more information.

This window can be fitted with:	See more
Click vent	p. 29
Integral blind	p. 29

VELFAC 200 Sidehung window



2-leaf window

This window is opened by turning the handle to a horizontal position and pushing the sash outwards. The window opens to 90° and is equipped with a friction arm which allows the sash to be held in any position between closed and fully open.

Double leafed windows can be supplied with different types of mullion - see page 25 for more information.

Friction arm adjustment. The friction arm, found at the bottom edge (or occasionally top), can be adjusted by turning the friction bolt using a 4mm hexagon key.

Care. It is important to keep the guide rails free of dust and dirt by using a soft brush or cloth (2). The guide rails should not be oiled as this will accumulate dust and dirt, and remove friction. The hinges require oiling at least once a year using acid-free oil. In order to ensure the hinges are properly lubricated, the window should be opened and closed several times during and after oiling. (3).

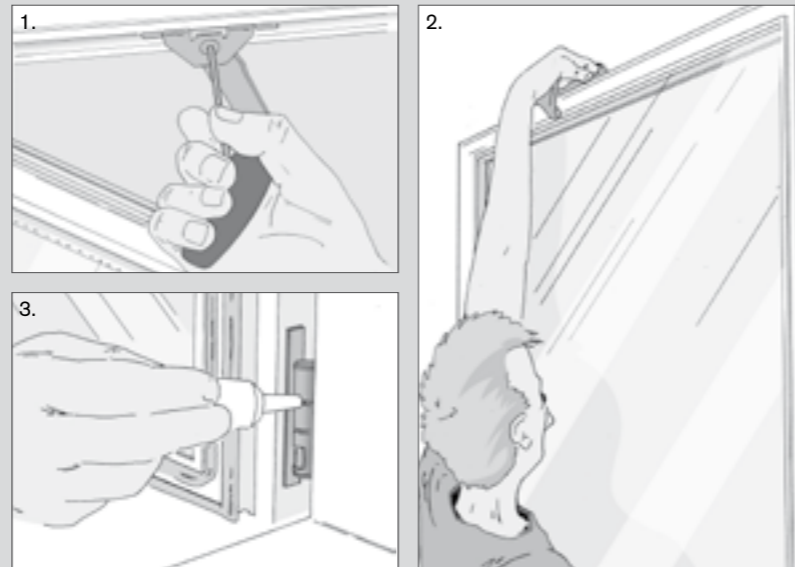

This window is equipped with:	See more
Espagnolette handle	p. 28
Ventilation position	p. 28
Friction arm	p. 29

It can also be fitted with:	See more
Espagnolette handle with child-lock	p. 28
Espagnolette handle with lock	p. 28
Espagnolette handle for cylinder lock	p. 28
Electric opener for remote operation	p. 28
Safety restrictor	p. 29
Window stay	p. 29
PN-fitting	p. 29
Lockable restrictor	p. 29
Click vent	p. 29
Integral blind	p. 29

VELFAC 200 Sidehung projecting window

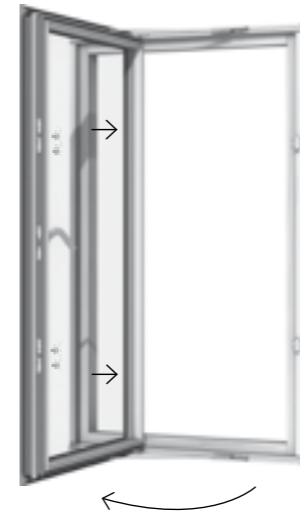

This window opens by turning the handle to a horizontal position and pushing the sash outwards.

Friction adjustment. Friction in the guide rails can be adjusted by turning the screws at the top of the sash with a 4mm hexagon key (1).

Cleaning. When the sash is fully opened, a gap is formed at the hinge side. This allows the external side of the sash to be cleaned from inside the building.

Care. Guide rails should be kept free of dust or dirt by cleaning with a soft brush or cloth. (2 + 3). The guide rails should be sprayed with teflon-based lubricating oil or a similar product once a year, as a minimum (never all-round lubricating oil!).

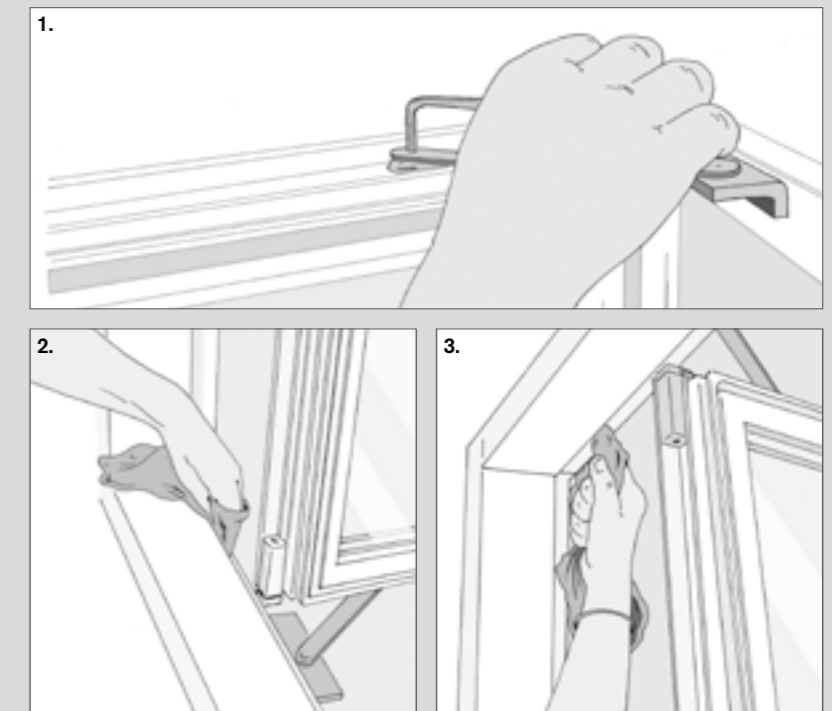

This window is equipped with:	See more
Espagnolette handle	p. 28
Ventilation position	p. 28
Friction arm	p. 29

It can also be fitted with:	See more
Espagnolette handle with child-lock	p. 28
Espagnolette handle with lock	p. 28
Espagnolette handle for cylinder lock	p. 28
Electric opener for remote operation	p. 28
Safety restrictor	p. 29
Window stay	p. 29
PN-fitting	p. 29
Lockable restrictor	p. 29
Click vent	p. 29
Integral blind	p. 29

VELFAC 200 Reversible window

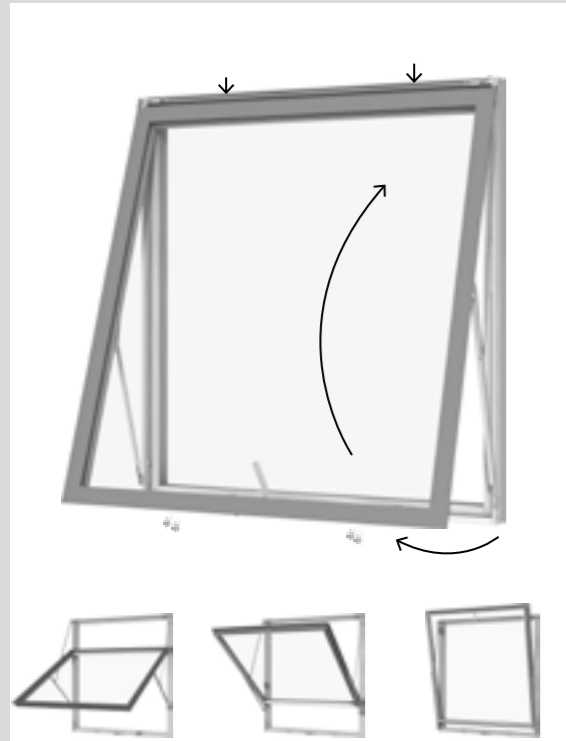

The window opens by turning the handle to a vertical position and pushing the sash outwards until the safety restrictor engages at an opening of 5-10cm.

Friction arm adjustment. Friction is adjusted by equally turning the screws at the sides of the sash anti-clockwise using a 3mm hexagon key (1). It is important that the screws are evenly tightened in both sides, to keep the sash level and square.

Cleaning. The external side of the window can be cleaned from inside the building by reversing the sash. Open the window until the safety restrictor is activated. Pull back the window slightly and detach the restrictor (2). Push the window outwards - **DO NOT LEAN OUT** while doing so. When pushed outwards, the top of the sash can be pulled gently downwards toward the bottom of the window. The sash is fully reversed when the catch engages to keep it in the cleaning position (3). Large reversible windows have an additional safety arm which is to be moved outwards and fixed to the frame to ensure the sash is stable before cleaning (4). When the sash has been cleaned, the catch (3) and eventual arm (4) are disengaged and the bottom of the sash is guided back towards the top (2). The safety restrictor will automatically re-engage when the sash is closed. Never leave the window unattended while the restrictor is disengaged!

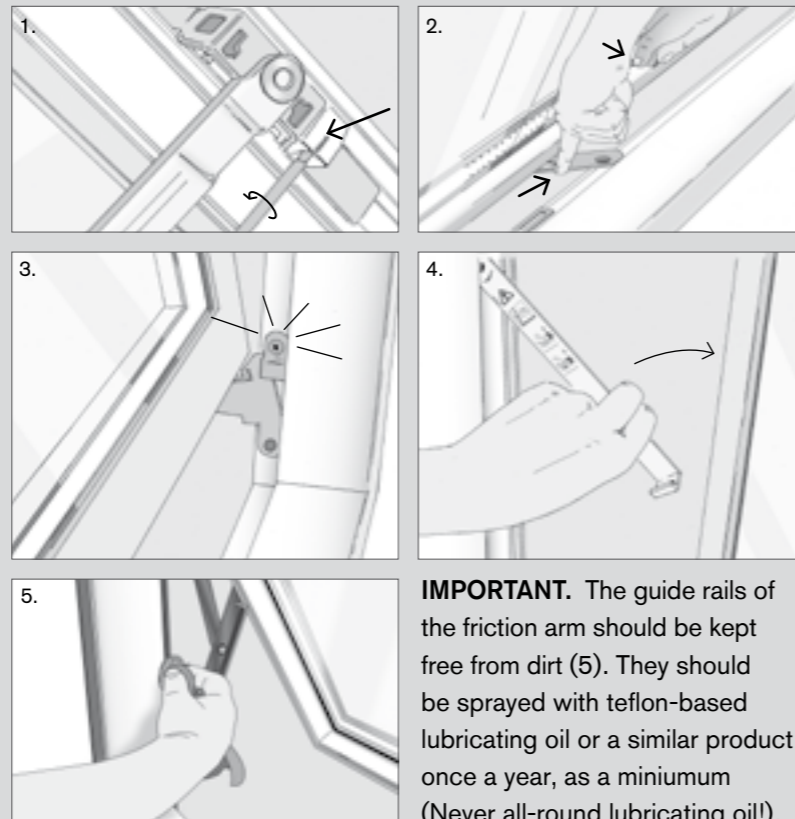

IMPORTANT. The guide rails of the friction arm should be kept free from dirt (5). They should be sprayed with teflon-based lubricating oil or a similar product once a year, as a minimum (Never all-round lubricating oil!).

This window is equipped with:	See more
Espagnolette handle	p. 28
Ventilation position	p. 28
Friction arm	p. 29
Safety restrictor	p. 16 + p. 29
Safety catch	p. 16

It can also be fitted with:	See more
Safety arm	p. 16
Espagnolette handle with child-lock	p. 28
Espagnolette handle with lock	p. 28
Espagnolette handle for cylinder lock	p. 28
Electric opener for remote operation	p. 28
PN-fitting	p. 29
Click vent	p. 29

Internal Sash for VELFAC 200 windows



The internal sash of a 2+1 window significantly improves acoustic and thermal properties. In order to constantly maintain this improvement, the internal sash must remain closed. It can be tophung or sidehung and can be equipped with either handles or screws depending on whether the sash will be opened in daily use or only for cleaning purposes.

The sidehung sash is opened by turning the small handle(s) and pulling inwards. The sidehung sash can be opened for both ventilation and cleaning. The tophung sash should only be opened for cleaning purposes and should be completely dismantled before commencing.

Dismounting a tophung internal sash. In order to remove the tophung sash, loosen the screws, hold down the top hinge pin (1) and tip out the sash - this operation will require 2 people.

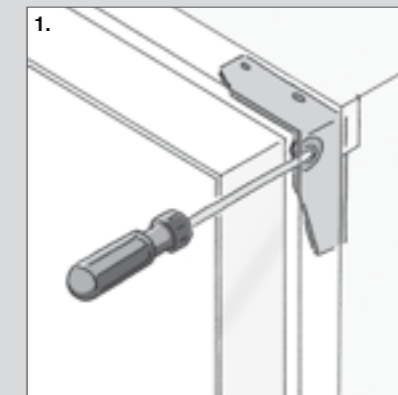

The internal sash is equipped with:
handles or screws.

VELFAC 200 Patio door



The patio door is opened by turning the handle to a horizontal position and pushing the door leaf outwards. The door opens to 90° and is equipped with a friction arm which allows it to be held in any position between closed and fully open. Doors can be fitted with a hinge to allow 180° opening but then cannot be fitted with a friction arm.

Double doors can be supplied with different types of mullion - see page 25 for more information.

Care. It is important to keep the guide rails free of dust and dirt by using a soft brush or cloth (1). The guide rails should not be oiled as this will accumulate dust and dirt, and remove friction. The hinges require oiling at least once a year using a teflon-based lubricating oil or a similar product. In order to ensure the hinges are properly lubricated, the patio door should be opened and closed several times during and after oiling (2).

Friction arm adjustment. The friction arm, found at the top edge, can be adjusted by turning the friction bolt using a 4mm hexagon key (3).

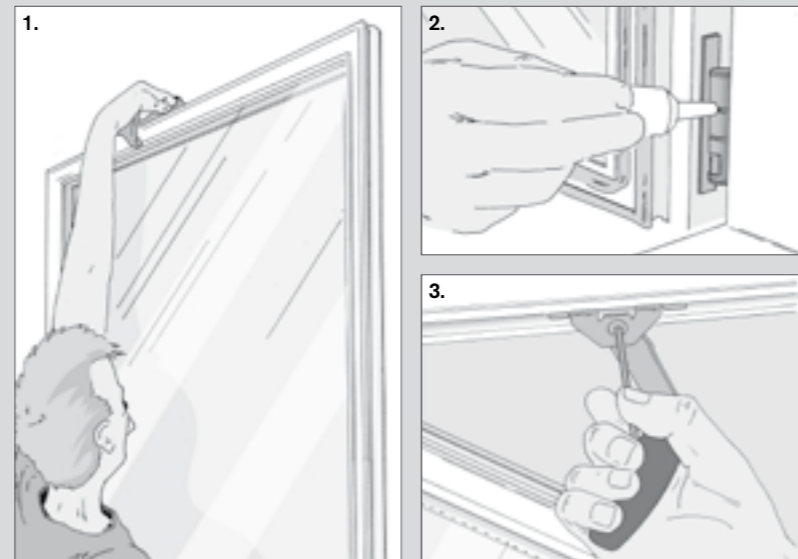

The patio door is equipped with:	See more
Espagnolette handle	p. 28
Ventilation position	p. 28
Friction arm	p. 29

It can also be fitted with:	See more
Espagnolette handle with child-lock	p. 28
Espagnolette handle with lock	p. 28
Espagnolette handle for cylinder lock	p. 28
PN-fitting	p. 28
Restrictor	p. 29
Window stay	p. 29
Lockable restrictor	p. 29
Click vent	p. 29
Integral blind	p. 29

VELFAC 200 Sliding door

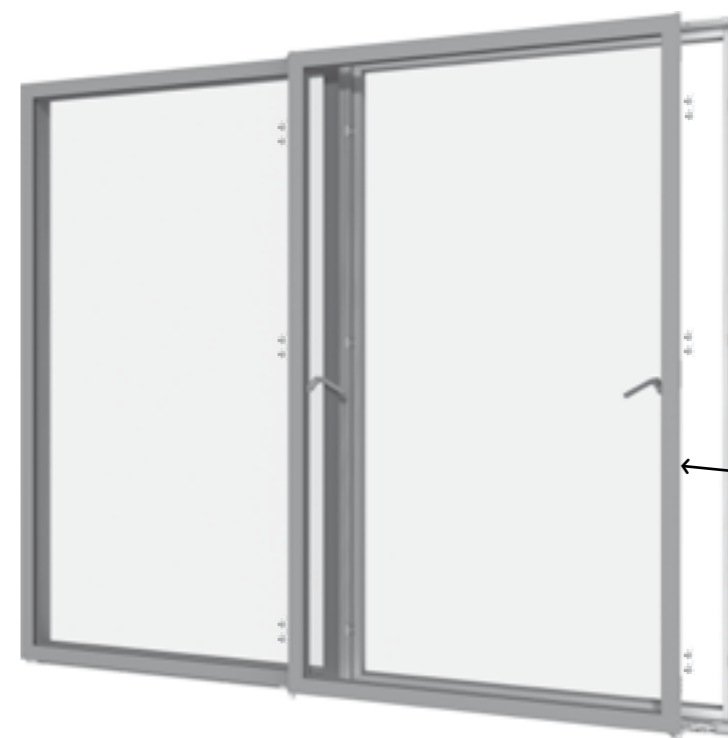

The sliding door is opened by turning the handles at the sides of the door leaf to a horizontal position. The door is then pushed outwards approximately 10cm and slid across. The door is closed by sliding across and pulling back toward the frame. The handles are then turned back to a vertical position.

Double sliding doors are supplied with French casement mullion - see page 25 for more information.

Care. The guide rails must be kept free from dust and dirt with a cloth or soft brush. (1). The front 'carriage' - the hinge that moves in the slide rail at the leading edge of the door - must be oiled at least once a year with a teflon-based lubricating oil or a similar product (2).

Adjustment is quite complicated and should be entrusted to a professional. Therefore no further elaboration of adjustment can be found in this brochure. Information about adjustment can be found in our installation guide, which can be downloaded at www.VELFAC.co.uk.

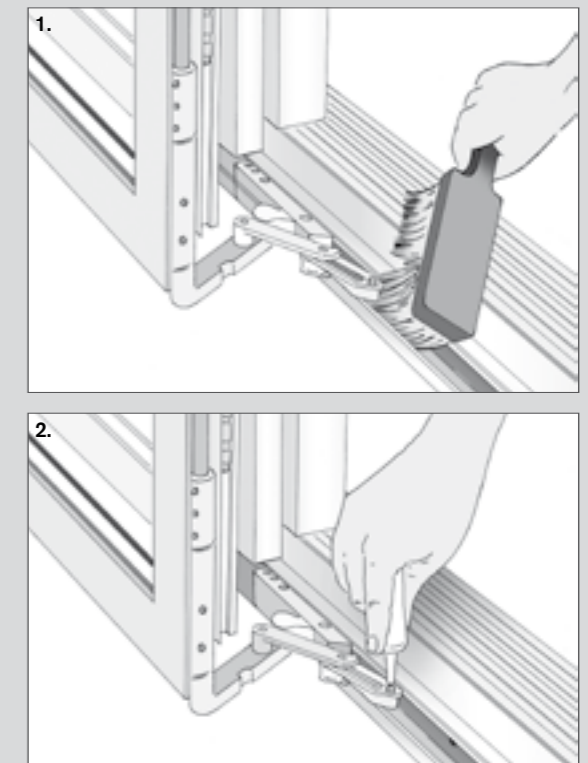

The sliding door is equipped with:	See more
Espagnolette handle	p. 28
Ventilation position	p. 28

It can also be fitted with:	See more
Espagnolette handle with child-lock	p. 28
Espagnolette handle with lock	p. 28
Espagnolette handle for cylinder lock (only for closing side)	p. 28
Click vent	p. 29

VELFAC 400i Tophung projecting window



This window is opened by turning the handle to a vertical position and pushing the sash outwards. Opening the window will provide a ventilation gap at the head.

Friction arm adjustment. Friction can be adjusted by turning the friction screws at the sides of the sash using a 4mm hexagon key (1). Each screw is adjusted equally to keep the sash level and square.

Care. Ensure that guide rails are free from dust and dirt (2). They should not be oiled as this will accumulate dust and dirt, and remove friction.



This window is equipped with:	See more
Espagnolette handle	p. 28
Ventilation position	p. 28
Friction arm	p. 29

It can also be fitted with:	See more
Espagnolette handle with child-lock	p. 28
Espagnolette handle with lock	p. 28
Espagnolette handle for cylinder lock	p. 28
PN-fitting	p. 29
Safety restrictor	p. 29
Lockable restrictor	p. 29
Click vent	p. 29

VELFAC 400i Fixed window



A fixed window cannot be opened and therefore requires no maintenance or adjustments of opening fittings.

Fixed windows can be converted to opening. Please call VELFAC After Sales Service on 01223 897100 (UK) or 01 421 5112 (IRL) for more information.

This window can be fitted with:	See more
Click vent	p. 29

VELFAC 400i Reversible window

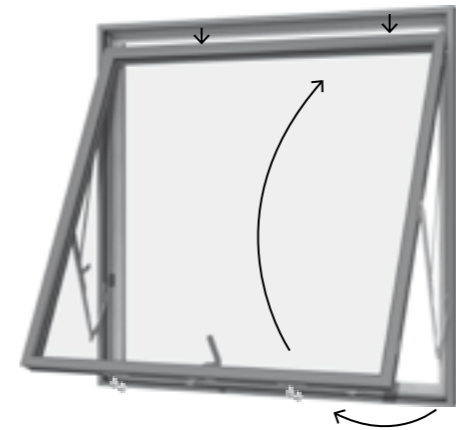

The window opens by turning the handle to a vertical position and pushing the sash outwards until the safety restrictor engages at an opening of 5-8cm. The window is not equipped with a friction arm, but the handle has a built-in ventilation position.

Cleaning. The external side of the window can be cleaned from inside the building by reversing the sash. Open the window until the safety restrictor is activated. Pull back the window slightly and detach the restrictor (1). Push the window outwards - DO NOT LEAN OUT while doing so. When pushed outwards, the top of the sash can be pulled gently downwards toward the bottom of the window. The sash is fully reversed when the one or two catches (depending on window size) engages to keep it in the cleaning position.

When the sash has been cleaned, the one or two catches are disengaged by pressing them outwards (2) so they will be free of the frame. Now the bottom of the sash is guided back towards the top. The safety restrictor will automatically re-engage when the sash is closed. Never leave the window unattended while the restrictor is disengaged!

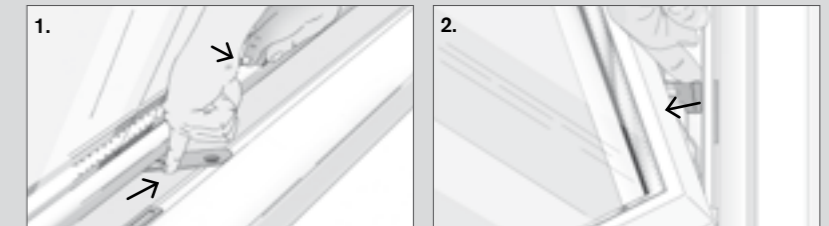

This window is equipped with:	See more
Espagnolette handle	p. 28
Ventilation position	p. 28
Safety restrictor and safety catch	p. 21

It can also be fitted with:	See more
Espagnolette handle with child-lock	p. 28
Espagnolette handle with lock	p. 28
Espagnolette handle for cylinder lock	p. 28
PN-fitting	p. 29
Lockable restrictor	p. 29
Click vent	p. 29

VELFAC 400i Sidehung window



2-leaf window

Cleaning tip. If you can reach the window from the ground, then open and clean it on both sides from the outside.

This window is opened by turning the handle to a horizontal position and pushing the sash outwards. The window opens to 90° and is equipped with a friction arm which allows the sash to be held in any position between closed and fully open.

2-leaf windows can be supplied with different types of mullion - see page 25 for more information.

Friction arm adjustment. If the window is fitted with a friction arm, you can adjust it by turning the friction bolt using a 4mm hexagon key. The friction arm can be located both at the top and at the bottom of the window - below it is shown at the top (1).

Care. The hinges require oiling at least once a year with a teflon-based lubricating oil or a similar product. In order to ensure the hinges are properly lubricated, the window should be opened and closed several times during and after oiling (2). It is important to keep the guide rails free of dust and dirt by using a soft brush or cloth. The guide rails should not be oiled as this will accumulate dust and dirt, and remove friction (3).

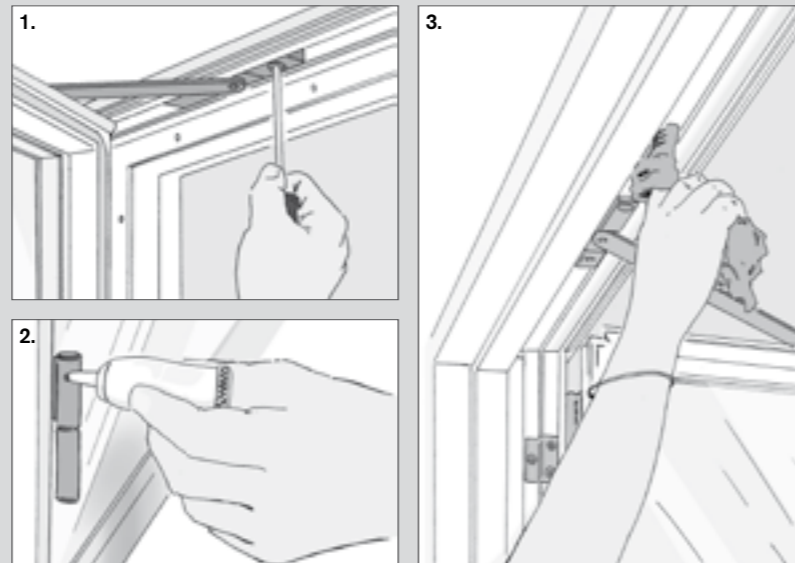

This window is equipped with:	See more
Espagnolette handle	p. 28

It can also be fitted with:	See more
Espagnolette handle with child-lock	p. 28
Espagnolette handle with lock	p. 28
Espagnolette handle for cylinder lock	p. 28
Ventilation position	p. 28
Safety restrictor	p. 29
PN-fitting	p. 29
Lockable restrictor	p. 29
Friction arm	p. 29
Click vent	p. 29

VELFAC 400i Sidehung projecting window

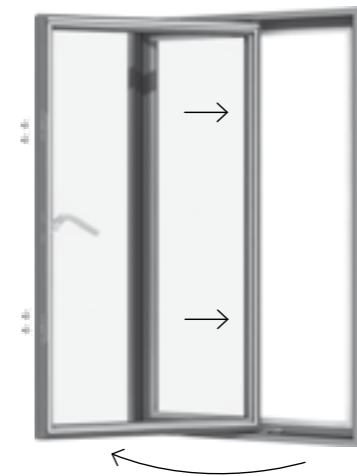

This window opens by turning the handle to a horizontal position and pushing the sash outwards.

Friction arm adjustment. If the window is fitted with a friction arm, friction in the guide rails can be adjusted by turning the screws at the top of the sash with a 3mm hexagon key (1).

Cleaning. The window is opened to approx. 90° and then turned to the outer position (135°-137°) from the hinge side. The outside of the window can now be cleaned from inside.

Care. Guide rails should be kept free of dust or dirt by cleaning with a soft brush or cloth. (2 + 3). The guide rails should be sprayed with teflon-based lubricating oil or a similar product once a year, as a minimum (never ordinary lubricating oil!).

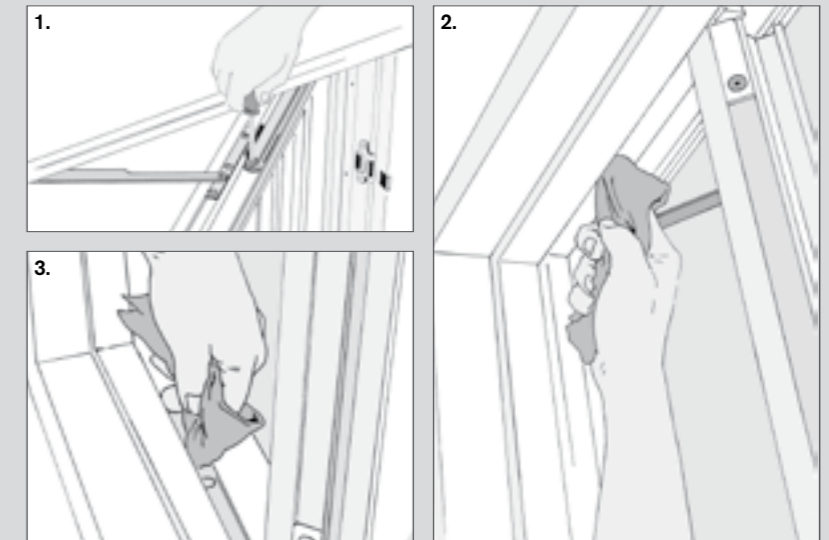

This window is equipped with:	See more
Espagnolette handle	p. 28

It can also be fitted with:	See more
Espagnolette handle with child-lock	p. 28
Espagnolette handle with lock	p. 28
Espagnolette handle for cylinder lock	p. 28
Ventilation position	p. 28
Safety restrictor	p. 29
Lockable restrictor	p. 29
PN-fitting	p. 29
Friction arm	p. 29
Click vent	p. 29

VELFAC 400i Patio door



The patio door is opened by turning the handle to a horizontal position and pushing the door leaf outwards. The door opens to 90° and is equipped with a friction arm which allows it to be held in any position between closed and fully open. Doors can be fitted with a hinge to allow 180° opening but then cannot be fitted with a friction arm.

2-leaf doors are equipped with French Casement. See page 25.

Care. It is important to keep the guide rails free of dust and dirt by using a soft brush or cloth (1). The guide rails should not be oiled as this will accumulate dust and dirt, and remove friction. The hinges require oiling at least once a year with a teflon-based lubricating oil or a similar product. In order to ensure the hinges are properly lubricated, the window should be opened and closed several times during and after oiling (2).

Friction arm adjustment. The friction arm, found at the top edge, can be adjusted by turning the friction bolt using a 4mm hexagon key (3).

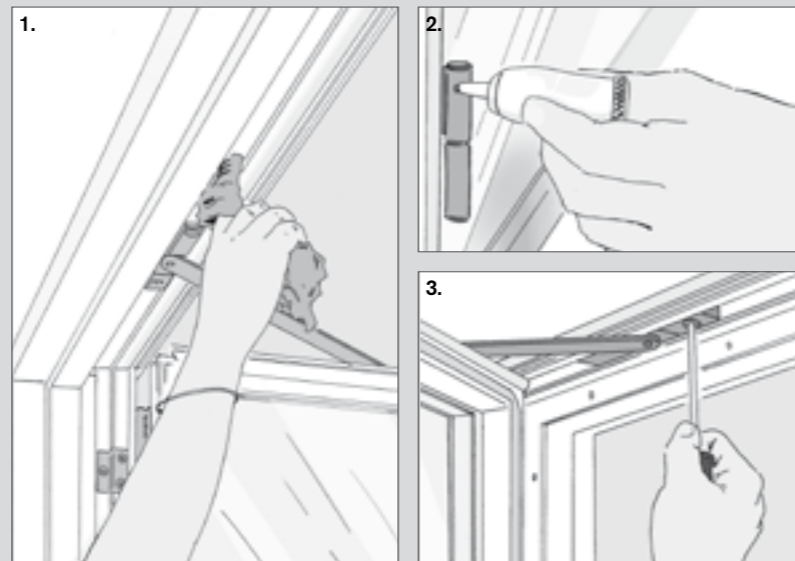

The patio door is equipped with:	See more
Espagnolette handle	p. 28
Ventilation position	p. 28
Friction arm	p. 29

It can also be fitted with:	See more
Espagnolette handle with child-lock	p. 28
Espagnolette handle with lock	p. 28
Espagnolette handle for cylinder lock	p. 28
PN-fitting	p. 29
Lockable restrictor	p. 29
Safety restrictor	p. 29
Click vent	p. 29

2-leaf VELFAC 200 and 400i windows and patio doors



Fixed mullion

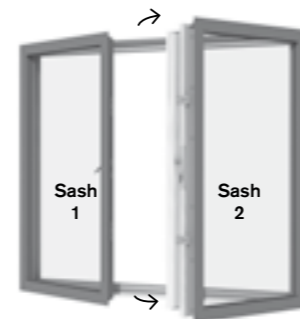

French Casement mullion



Removable (escape) mullion

A fixed mullion cannot be moved when both sashes are open.

The French Casement mullion is fixed to the leading edge of the Sash 2. Once Sash 1 has been opened, the mullion can be disconnected and Sash 2 subsequently opened. The mullion will move with the sash providing a clear opening for both sashes.

The mullion is disconnected by the mid-positioned flush bolt (1), or the barrel bolt (2) or the handle (3) and Sash 2 is opened. The French casement mullion must be re-engaged before closing Sash 1.

The removable mullion stays in the opening when the sashes are opened. In the event of fire it can be entirely removed by opening both sashes, loosening the barrel bolt (4) and push out the mullion.

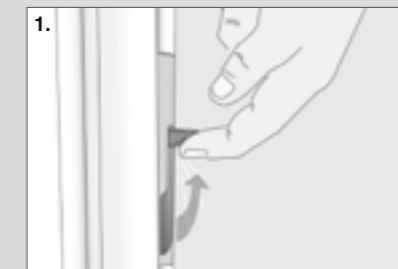

Flush bolt for French Casement mullion.



Top and bottom flush bolt for broad mullion (discontinued summer 2009).



Handle for narrow mullion (discontinued summer 2009).

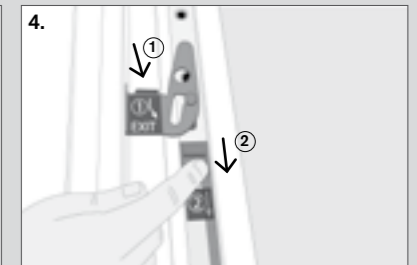

Barrel bolt for removable mullion.

VELFAC 100 Inward opening window and patio door



Sidehung

Bottomhung

In the following, the function of the inward opening patio door is described. The inward opening window is operated in a similar way.

An inward opening patio door is opened by turning the handle 90° from (1) to (2) and pulling the sash inwards (up to 90°). Make sure that the sash doesn't blow open and hit the door casing. The door is closed by pushing the door frame against the casing and turning the handle down to vertical position (1).

Ventilation position. The door allows a 10cm ventilation gap at the top by turning the handle 180° from (1) to (3) and tilting the door inward. Close the door by pushing the door frame against the casing and turning the handle down to vertical position (1).

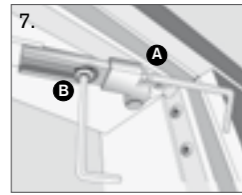
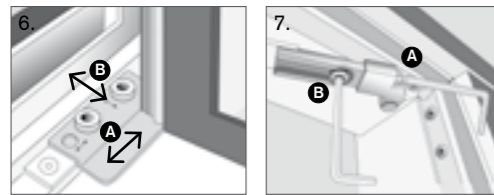
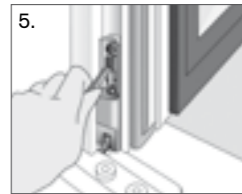
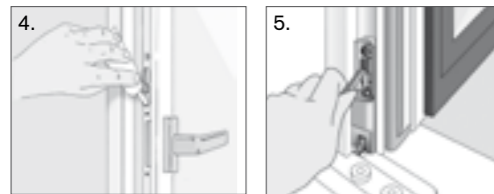
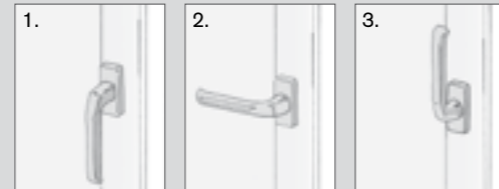

This window / door is equipped with:	See more
Handle	p. 26 + 28

This window / door can also be fitted with:	See more
Click vent	p. 29

2-leaf patio doors are fully opened by turning the handle from (1) to (2) and open the door. Then the barrel bolt is turned 180° at the top of the standing frame before it can be opened.

Care. All movable fittings require oiling at least once a year with a teflon-based lubricating oil or a similar product. In order to ensure that the parts are properly lubricated, the window should be opened and closed several times during and after oiling (4). The bottom hinge (5) is filled with lubricant and should not be oiled!

Adjustment of the sash.

1. Height is adjusted in the bottom corner hinge using a 4mm hexagon key (5)
2. You can adjust sideways by turning the screw in front in the bottom corner hinge (6A), and/or by turning the screw in the end of the scissor hinge located in the top frame corner, both with a 4mm hexagon key. (7A)

Adjustment of closing. If the window is difficult to close or if the gasket is not tight, then you are able to adjust the pressure in the following ways:

1. Turning the bottom corner hinge screw using a 4mm hexagon key (6B)
2. Turning the top scissor hinge screw while the window is tilted (7B)
3. Turning the locking pins on the side of the window with a Torx T15 screwdriver (8). Clock-wise to loosen and anti clock-wise to tighten.

VELFAC 600 Entrance door in wood/aluminium or wood



Inward opening panelled door



Outward opening panelled door Outward opening flush door

The entrance door opens to 180°. By default the door is delivered with 3 closing points. The top and bottom closing points are only activated when the handle is lifted after closing the door. Equally the handle must be lifted before turning the key or thumbturn. The door is also available with a 1 closing point solution.

Care. The hinges, lock and closing points require oiling at least once a year with a teflon-based lubricating oil or a similar product. In order to ensure they are properly lubricated, they should be activated several times during and after oiling. (1). On inward opening doors, the rainscreen should at least once a year be oiled with silicone lubricant. The door leaf of a flush door should be painted with 100% water-based acrylic paint every 3 years to maintain the finish.

Adjustment. The closing pressure may be adjusted by relocating the front section of the strike plate. The screw fittings are undone using a Torx T10 screwdriver, the pins on the front section removed, and the plate relocated (2).

The door leaf can be adjusted sideways by loosening the hinge screws using a 3mm hexagon key, and the door adjusted to suit (3).

The height of the door leaf may be adjusted by turning the thread underneath the pivot of the middle hinge using a 6mm hexagon key (4).

2-leaf doors. To open both leaves, the handle must be operated and the first leaf opened. Then the lever at the edge of second leaf must be operated to dis-engage the flushbolt (5).

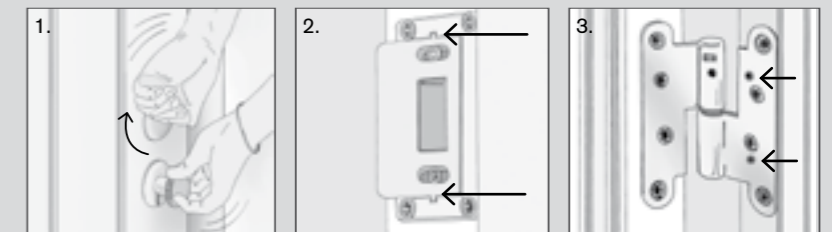

Handles. If you choose another handle than what VELFAC offers for your entrance door, you have to make sure that it fits with the drilling template, which is situated on the side jamb of the door, else the lock will be ruined.

This door is equipped with:	See more
Click vent	p. 29

There is also an **entrance door in aluminium**, which is primarily used as an entrance door in shops, office buildings, larger multi-story buildings and institutions. 2-leaf aluminium doors are opened by detaching the flush bolts (6). See more in our instructions for installation, which can be downloaded at www.VELFAC.co.uk.

Handles and remote operation for VELFAC 200 and 400i windows and patio doors

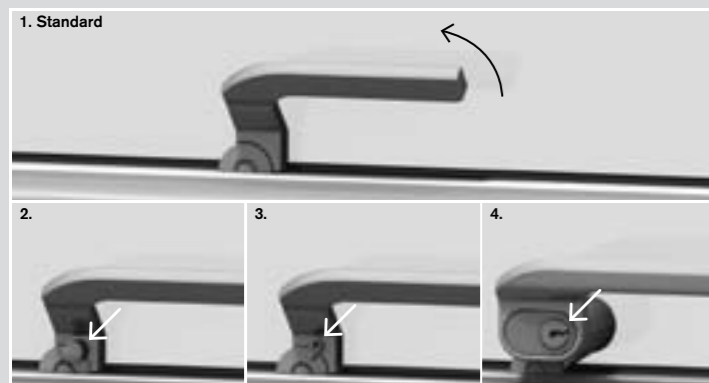

► **The espagnolette handle** is tipped upwards to open the window. A **ventilation position** is obtained by pushing out the window approx. 1 cm and re-engaging the handle.

▪ **Espagnolette handles with child-locks** can only be opened when the button below the handle is pressed while the handle is turned. The child-lock will automatically re-engage when the sash is closed.

▪ **Espagnolette handle with locks** are equipped with a small, removable key.

▪ **Espagnolette handles for cylinders** can fit cylinders as part of a key strategy around a building.

► **Care.** The bolts of the handle require oiling with long-lasting lubrication oil at least once a year, while operating the handle to ensure proper lubrication.



► **Catch** (only VELFAC 400i) is often chosen when it fits in with the style of the building - for instance in connection with renovation of classical buildings.

The catch can be tightened by turning the screw eye of the window. The catch does not have a ventilation position - you can use a window stay instead (see p. 29).



► **Remote operation** (only VELFAC 200) is operated via a panel on the wall - or a remote control. The window is opened with the arrow-up button, and closed with the arrow-down button. The remote comes in two versions: The window moves while the button is pressed down - or by one short press and stop with the middle button. The metal chain of the remote operation should be kept clean.

Safety fittings and other accessories for VELFAC 200 and 400i windows and patio doors



► **The safety restrictor** automatically engages when the sash is opened to approximately 4cm. To open further, the sash is pulled slightly back while disengaging the restrictor.



► **The PN-fitting** makes it difficult for unwanted guests to enter if the window is open. When opening the window, the arm is lifted and re-engaged when the required opening is achieved. The arm is raised to a vertical position to disengage, allowing the sash to open fully.



► **Window stay.** The arm is fitted to the wood frame and when used, is hooked into an eyelet on the sash to achieve an opening of approximately 130mm.



► **Integral blinds** within the double glazed unit are operated manually using a cord.

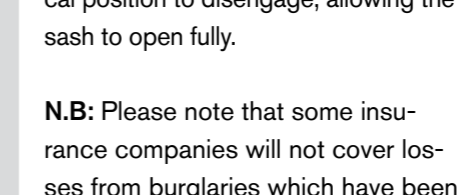

N.B: Please note that some insurance companies will not cover losses from burglaries which have been committed when windows have been left in a ventilation position.



► **Window stay.** The arm can keep the window open in at 90°. In windy conditions, the window should be kept closed.



► **The lockable restrictor** limits the opening of the sash to 1.5-10cm. It is possible to disengage the restrictor: in VELFAC 200 windows by turning the lock through 90° with a 5mm hexagon key; in VELFAC 400i windows by using the special key delivered along with the window. Now the restrictor arm may be pushed out of the gliding rail. The lock must always be re-engaged after use. The gliding rails should frequently be cleaned from dirt.



► **The friction arm** will retain the open window in any ventilation position under normal weather conditions. If it is really windy the ventilation position in the handle is to be used instead (see p. 28). The friction arms are adjusted by the factory to fit the size of the window. If the window opens too tight or too loose, the friction arm may be adjusted (see more by the relevant type of window, p. 12-24).



► **Click vent.** The click vent is fitted within the frame and provides background ventilation. The vent is opened by pressing one or both ends marked with circles.

The click vent can be situated either in the side of the sash (VELFAC 200, 400i and 600) or in the top of the sash (VELFAC 100).

Handles for VELFAC 100 inward opening elements

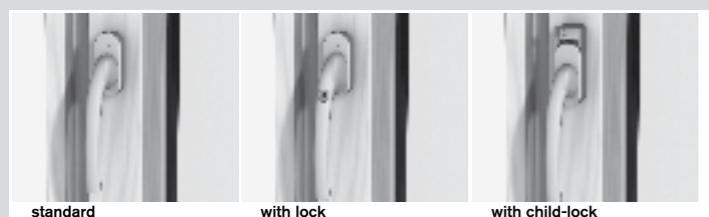

► **Operation.** The handle has 3 positions: Closed, open and ventilation position.

▪ **Handle with lock** can in closed condition be locked with a small, removable key.

▪ **Handle with child-lock** can only be opened when the button above the handle is pressed downwards while turning the handle. The child-lock will re-engage when the window/patio door is closed.

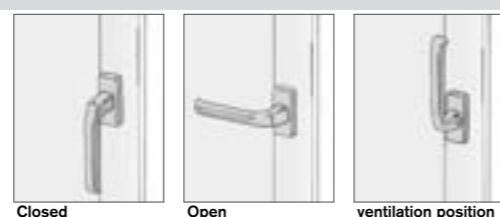

Operation failure, damage or break-ins

Operation failure. If the window cannot be easily operated, check for any outside obstructions and remove. If the window resists closing, check for obstructions between the moving aluminium sash and the fixed timber mainframe. Ensure that no debris is obstructing the slide motion of the moving arm.

There are several steps you can follow to ensure your windows work properly.

Oil at least once a year with a few drops of teflon-based lubricating oil or a similar product:

- the bolts of the espagnolette handle (should be cleaned first)
- hinges
- locks and closing points in facade doors
- moveable fittings in the inward opening windows and balcony doors

Look under the current window or door where you must lubricate (see page 12-27).

Weather seals, gaskets and glazing beads. Check once a year that they are intact and functioning, and that there is no paint or lacquer on them. Paints/laquers make them stiff and they work best when they retain their smooth surface. For windows and doors to move easily you can lubricate the seals with silicone. New glass, seals, gaskets, glazing beads, valves and gaskets are available from VELFAC After Sales Service Department.

Adjustment. Are windows or doors operating poorly, or are the sashes hanging a little, often an adjustment can remedy the problem.

Damage or break-ins. If the window is operable after being damaged by forced entry or accident, it should be closed and secured. If the glass unit has been broken, any remains should be carefully removed taking all necessary safety precautions i.e. wearing protective clothing such as gloves, safety glasses, suitable footwear etc.

To restore building security, temporary glazing material (such as plywood or similar) may be glazed into the aluminium sash profile until a replacement glass unit is available.

In order to ensure your product warranty is maintained, please contact VELFAC After Sales Service to arrange repair of windows or to supply and fit replacement glass units.

VELFAC After Sales Service

A national system of service support ensures a fast and efficient response to any issues which may arise. A wide range of modifications and repairs are possible through VELFAC After Sales Service including:

- Supply and installation of replacement double-glazed units
- Supply and installation of replacement components
- Repair of damaged wood frames or aluminium sashes
- Conversion of fixed windows to opening
- Retro-fitting of opening restrictors
- Retro-fitting of electric motor openers

All our Service Engineers undergo a comprehensive training programme that equips them with interpersonal and problem solving skills, and in depth product knowledge. Using a VELFAC Engineer will ensure your 12 Year Product Warranty is maintained.

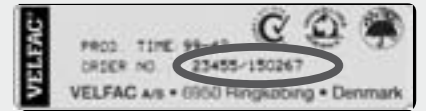

► **Order number.** All VELFAC windows carry a unique identity tag to enable immediate tracing of spare parts should damage occur.